



# MARTIN® PV Piston Vibrators

*Martin Engineering's PV Series Pneumatic Piston Vibrators deliver high-impact linear force to evacuate difficult materials from storage vessels.*

*MARTIN® PV Vibrators provide an economical solution to bulk solids flow problems. Used with filtered and lubricated air, they require only minimal maintenance.*



## Performance Data

		Model					
		PV-1.25	PV-2	PV-2.5	PV-3	PV-4	
20 psi (1.38 bar)	Speed * VPM	2600	1400	700	575	450	
	Force	lb	35	96	147	218	350
		kg	16	44	67	99	159
	Air Consumption	cfm	—	8	9	14	28
L/sec.		—	3.78	4.25	6.61	13.21	
40 psi (2.76 bar)	Speed * VPM	3800	2000	1150	1000	525	
	Force	lb	71	190	288	424	700
		kg	32	86	131	192	318
	Air Consumption	cfm	—	16	21	30	44
L/sec.		—	7.55	9.91	14.16	20.76	
60 psi (4.14 bar)	Speed * VPM	4600	2800	1500	1300	600	
	Force	lb	106	283	430	630	1000
		kg	48	128	195	286	454
	Air Consumption	cfm	8	20	34	43	62
L/sec.		3.78	9.44	16.04	20.29	29.26	
80 psi (5.51 bar)	Speed VPM	5400	3200	1800	1400	700	
	Force	lb	142	376	571	835	1400
		kg	64	171	259	379	635
	Air Consumption	cfm	14	26	58	70	80
L/sec.		6.61	12.27	27.37	33.03	37.75	

\* Speed may not be vibrations per minute (VPM), but cycles per minute.

## Selection Guide

Vibrator selection is based on the vessel construction and/or the characteristics and weight of material in the sloped portion of the storage vessel.

Model	Weight of Material in Slope Portion of Vessel		Thickness of Vessel Wall		
	lb	kg	in		mm
PV-1.25	20,000	9,070	0.07-0.125	1/16-1/8	1.5-3
PV-2	30,000	13,607	0.125-0.25	1/8-1/4	3-6
PV-2.5	40,000	14,140	0.125-0.25	1/8-1/4	3-6
PV-3	60,000	27,215	0.25-0.5	1/4-1/2	6-13

## Additional PV-3 Mount

Model	P/N	Ship Wt. lb (mm)	TBM Mount P/N	Ship Wt., lb (mm)
PV-3	21287	55 (24.9)	22522	40 (18.1)

Dimension—in (mm)

Models	A	B	C	D	E	F	G	H	J	K**	L	M**
PV-1.25	5.75 (146)	4.00 (102)	4.19 (106)	0.84 (21)	1.84 (147)	4.5 (114)	0.62 (16)	1.69 (43)	—	0.25 (6)	0.50 (13)	0.25 (6)
PV-2	8.87 (225)	6.00 (152)	5.75 (146)	1.56 (40)	2.75 (70)	7.5 (190)	0.75 (19)	2.47 (63)	—	0.25 (6)	0.62 (16)	0.25 (6)
PV-2.5	11.62 (295)	7.25 (184)	6.19 (157)	6.00 (152)	3.75 (95)	9.5 (241)	1.0 (25)	3.19 (81)	3.50 (89)	0.50 (13)	0.75 (19)	—
PV-3	12.00 (305)	8.62 (219)	7.69 (195)	1.75 (44)	4.00 (102)	9.5 (241)	0.75 (19)	3.25 (83)	3.50 (89)	0.75 (19)	0.75 (19)	0.5 (13)
PV-4	12.00 (305)	11.88 (301)	7.38 (187)	6.00 (152)	4.25 (108)	10.0 (254)	2.50 (63)	4.40 (112)	4.00 (102)	0.75 (19)	—	—

\*\* K = Inlet (NPT) M = Exhaust (NPT)

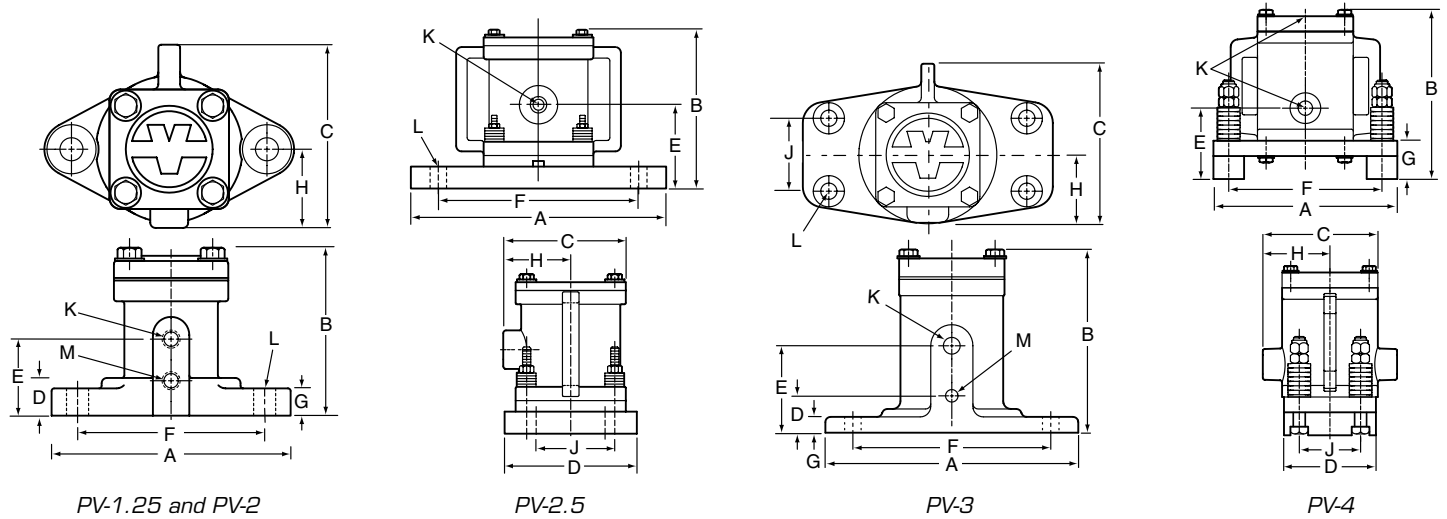

PV Piston Vibrators			With Liner		Mounts				Mounting Kit	
Model	P/N	Ship Wt. lb (kg)	P/N	Ship Wt. lb (kg)	Channel Mount P/N	Ship Wt. lb (kg)	Clamp Blocks P/N	Ship Wt. lb (kg)	P/N	Ship Wt. lb (kg)
PV-1.25	N/A	6 (2.7)	12883	6.0 (2.7)	29928-01	22 (10.0)	12958-03	3 (1.4)	29810	5 (2.3)
PV-2	12889	18 (8.1)	19862	18.5 (8.4)	29928-02	22 (10.0)	12958-04	4 (1.8)	29811	5 (2.3)
PV-2.5	18105	51 (20.4)	18581	52.0 (23.6)	30643	40 (18.1)	12958-05	8 (3.6)	29812	5 (2.3)
PV-3	21287	55 (24.5)	23990	56.25 (25.5)	30643	40 (18.1)	12958-05	8 (3.6)	29812	5 (2.3)
PV-4	17757	120 (54.4)	21035	122.5 (55.6)	NA	60 (27.2)	N/A	—	29813	5 (2.3)



Patents and patents pending. © Registered trademark of Martin Engineering Company in the U.S. and other select locations. Additional information can be obtained at [www.martin-eng.com/trademarks](http://www.martin-eng.com/trademarks).

QUALITY MANAGEMENT SYSTEM  
 CERTIFIED BY DNV  
**ISO 9001**

MARTIN ENGINEERING USA  
 One Martin Place  
 Neponset, IL 61345-9766 USA  
 800-544-2947 or 309-594-2384  
 FAX: 309-594-2432  
[www.martin-eng.com](http://www.martin-eng.com)