



# MARTIN® MP3

## Non-Impacting Linear Railcar Vibrator

*This lightweight, low-noise system combines a non-impacting linear vibrator with a urethane mounting shoe. The **MARTIN® MP3 Non-Impacting Linear Railcar Vibrator** provides up to 1000 lbs (454 kg) of force to unload the most stubborn materials.*



### BENEFITS

- Improves Efficiency**  
 Linear vibrator provides powerful force to boost material flow.
- Low Noise**  
 Non-impacting vibrator and urethane mounting shoe eliminate metal-to-metal noise.
- Easy to Handle**  
 Lightweight vibrator and shoe make mounting/ dismantling a "no-strain" procedure.
- Small But Mighty**  
 Compact vibrator and mount assembly provides plenty of power to unload the most stubborn materials.
- Saves Your Ears**  
 No hearing protection required; non-impacting vibrator on urethane foot produces only 80-85 db.
- Gives Your Back a Break**  
 Vibrator and wedge system weighs only 33 lb (15 kg), reducing risk of injury from manhandling large, unwieldy vibrators into railcar brackets.
- Saves Your Energy**  
 Air-efficient design operates on air supply from 45 to 95 psi (3.1 to 6.5 bar); consumes only 15 cfm at 90 psi (425 L/min at 6.2 bar).
- Guaranteed Performance**  
 MP3 Vibrator is covered by Martin Engineering's *Absolutely, Positively, No Excuses* Guarantee.

### SPECIFICATIONS

Supplied Pressure <i>psi (bar)</i>	Operating Speed <i>VPM</i>	Force Output <i>lb (kg)</i>	Air Consumption <i>cfm (L/min)</i>	Noise Produced <i>db</i>
40 (2.75)	2100	350 (159)	7 (198)	80
60 (4.14)	2500	650 (295)	11 (311)	83
*80 (5.16)	2800	1000 (454)	15 (425)	85

\* Suggested Air Pressure for Operation

**DIMENSIONS—in. (mm)**

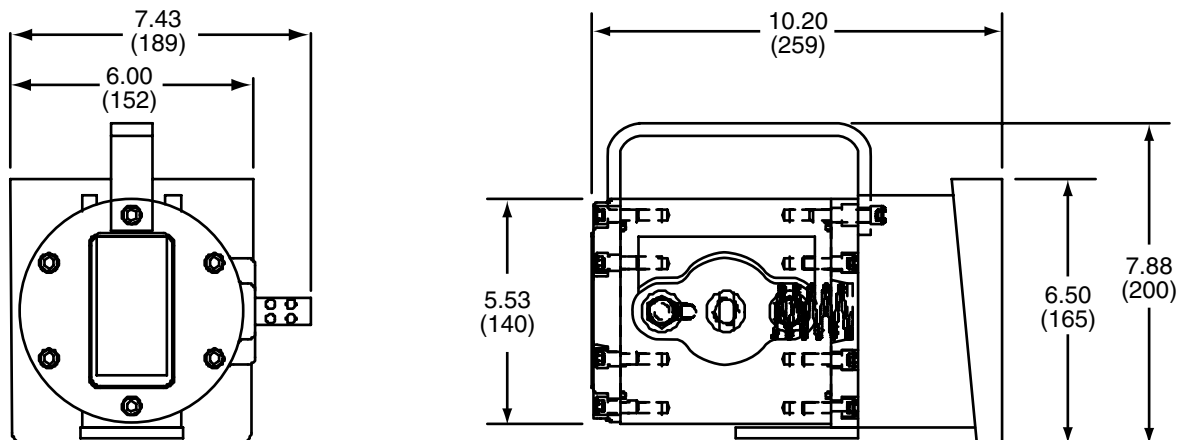

**NOTES**

- Unit weight: 33 lb (15 kg).
- All units require FRL Kit (Air Line Filter/Regulator/Lubricator) for proper operation.
- Suggested operating temperature 30°F (-1°C) and above.

**ORDER INFORMATION**

MP3 Railcar Vibrator and Mount	P/N 36889
3/8" FRL Kit	P/N 29809
Lubrication	P/N 14766



**MARTIN ENGINEERING USA**  
 One Martin Place  
 Neponset, IL 61345-9766 USA  
 800-544-2947 or 309-594-2384  
 FAX: 309-594-2432  
[www.martin-eng.com](http://www.martin-eng.com)

Patents and patents pending, © Registered trademark of Martin Engineering Company in the U.S. and other select locations. Additional information can be obtained at [www.martin-eng.com/trademarks](http://www.martin-eng.com/trademarks).

**QUALITY MANAGEMENT SYSTEM  
 CERTIFIED BY DNV**  
**ISO 9001**