



# MARTIN® DC Truck Vibrator

Unload your truck bed problems with the lowest priced vibrators in the industry. Martin Engineering's economical **MARTIN® DC Truck Vibrators** improve unloading efficiency without damage to truck box or dump mechanism.



## BENEFITS

- Maintenance-Free**  
 Sealed ball bearings are permanently lubricated.
- Satisfaction Guaranteed**  
 Longest life in the industry. Three-Year Warranty on motor (intermittant duty) and Life of the Vibrator Warranty for the bearings guarantees your satisfaction.
- Models To Match Your Truck and Load**  
 Choose from 12- or 24-volt motor; models match force to output requirements.
- Your Best Vibrator Value**  
 Shop and compare! MARTIN® DC Truck Vibrators feature the lowest price in the industry, GUARANTEED!



## NOTES

Weatherproof Motor provides durable service.

Frequency and Force output to match your truck and load. To change output, exchange weights free!

Sealed Ball Bearings require no lubrication. Bearings are guaranteed for life.

Unibody Vibratory Head guarantees weather-proof performance.

Lightweight Aluminum Housing provides high force-to-weight ratio.

Comes complete with 50 feet of 4AWG cable, solenoid, push button switch, steel or aluminum mount plate, and hardware. Options include circuit breaker and cable kit.

## APPLICATIONS

- Dump Trucks (On- and Off-Road)
- Fertilizer, Cement, Coal, and Fly Ash Trailers
- Ready-Mix Trucks and Concrete Pumps
- Spreader Trucks

## MATERIAL CHARACTERISTICS

- Sticky
- Wet
- Frozen
- Fibrous

## SPECIFICATIONS

Truck Capacity <i>yd<sup>3</sup></i> <i>[m<sup>3</sup>]</i>	Model	Force		Unbalance		* RPM	Ship Wt.		P/N
		<i>lb</i>	<i>[kg]</i>	<i>in-lb</i>	<i>[kg-mm]</i>		<i>lb</i>	<i>[kg]</i>	
2-5      [1.5-3.8]	DV2.5-412	2508	[1137]	4	[46]	4580	48	[21.8]	36296-412K
5-10      [3.8-7.6]	DV2.5-612	3033	[1376]	6	[69]	4220	49.5	[22.5]	36296-612K
10-16      [7.6-12]	DV2.5-812	3929	[1782]	8	[92]	4160	52	[23.6]	36296-812K

\* Data reflects results from simulated truck body mount.

DIMENSIONS—in. (mm)

A	B	C	D	E	F Ø	G	H
11.85 (301)	7.21 (183)	10.97 (279)	10.5 (267)	8.5 (216)	.812 (21)	6.43 (163)	2.89 (73)

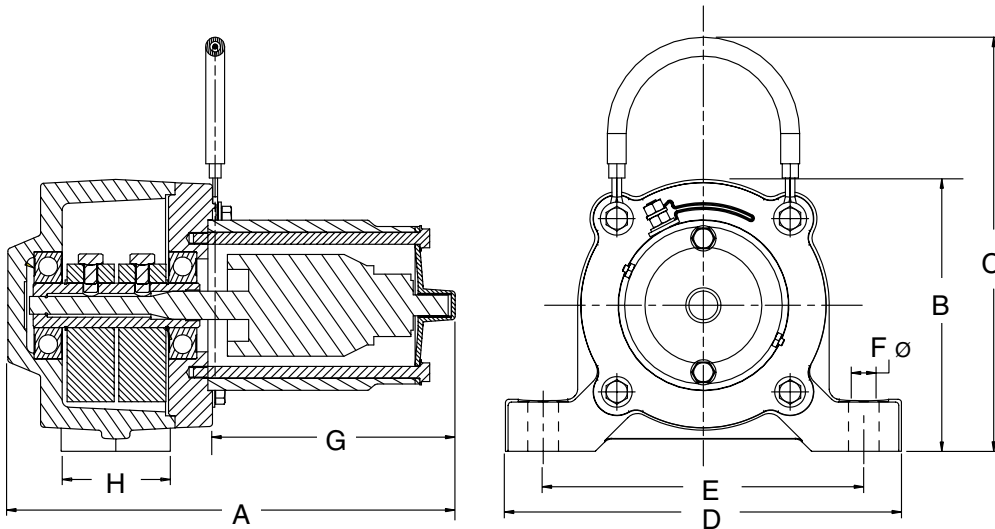

Martin Engineering's DC Truck Vibrators are designed for intermittent duty. Continuous operation may cause motor to overheat. Recommended Duty Cycle is 30 seconds (maximum) ON time, followed by 1 minute (minimum) OFF time.

Contact Martin Engineering for price and delivery.

ORDER INFORMATION

NOMENCLATURE

**36296-6 12 K S C**

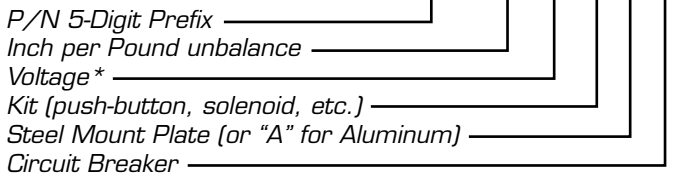

\* 24-Volt DC Truck Vibrators also available.

Thermal Circuit Breaker, 60 Amp 36472-60



**MARTIN ENGINEERING USA**  
 One Martin Place  
 Neponset, IL 61345-9766 USA  
 800-544-2947 or 309-594-2384  
 FAX: 309-594-2432  
[www.martin-eng.com](http://www.martin-eng.com)

Patents and patents pending, © Registered trademark of Martin Engineering Company in the U.S. and other select locations. Additional information can be obtained at [www.martin-eng.com/trademarks](http://www.martin-eng.com/trademarks).

**QUALITY MANAGEMENT SYSTEM  
 CERTIFIED BY DNV  
 ISO 9001**